

# POCLANE



## PLX39U MINI EXCAVATOR



Model	: YANMAR 3TNV88F
Rated Power	: 25 HP /2400rpm
Operating Weight	: 3900kg
Bucket Capacity	: 0.13 m <sup>3</sup>

# Technical Specifications

## ENGINE

Model	YANMAR 3TNV88F
No. of cylinder	3
Max. Torque/Speed	89/1400N·m/rpm
Displacement	1.7L

## HDRAULIC SYSTEM

Max. Main Pump Flow	97 LPM
Main Safety Valve Pressure	24 MPa

## MAIN PERFORMANCE

Bucket Digging Force	31kN
Arm Digging Force	19kN
Force Max. Traction	32kN
Rotary Speed	10 r/min
Gradeability	30°
Ground Pressure	32kPa

## BUCKET

Type	Backhoe bucket
Bucket capacity	0.13m <sup>3</sup>
Bucket width	650mm

## DRIVE SYSTEM

Carrier roller qty	1x2
Track roller qty	2x4
Track shoes	2x44
Travel speed	2.4/4.4 km/h
Ground clearance	1295mm
Grade ability	≤30°

## OPERATING WEIGHT & GROUND PRESSURE

Shoe width	300mm
Ground pressure	32kPa
Operating weight	3880kg

## REFILLING CAPACITIES & LUBRICATIONS

Fuel tank	50L
Cooling system	7L
Engine oil	6.77L
Hydraulic oil tank	40L
System capacity	40L

## SWING SYSTEM

Swing speed	0-9r/min
-------------	----------

## WORKING RANGE

A Max. digging height	4910
B Max. dumping height	3545
C Max. digging depth	3000
D Max. vertical digging depth	2690
E Max. digging distance	2475
F Max. digging radius at ground level	5500
G Tail swing radius	860
H Maimum dozer lift height	445
I Maximum dozer dig depth	370

## DIMENSIONS (boom : 2540mm arm : 1400

A Overall length	4880
B Ground contact lenght (Transportation)	3360
C Overall height (to top of boom)	1880
D Overall width	1740
E Overall height (to top of cab)	2550
F Counter weight ground clearance	595
G Ground clearance	295
H Tail swing radius	860
J Crawler wheel base	1635
K Track length	2155
L Track gauge	1440
M Tack width	1740
N Shoe width	300
O Bonnet height	1550
P Revolving frame width	1615

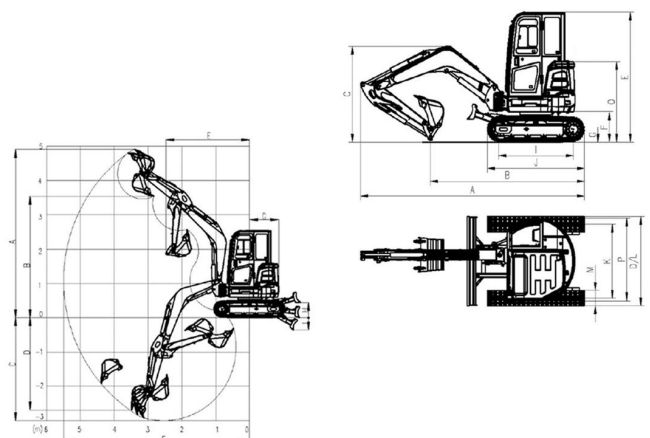

\* THE SPECIFICATIONS ARE SUBJECT TO CHANGE WITHOUT NOTICE. THE PICTURES MAY INCLUDE OPTIONS. THE ACTUAL COLOR & APPEARANCE OF THE PRODUCT MAY DIFFER FROM WHAT IS SHOWN.



POCLANE

**POCLANE CONSTRUCTION EQUIPMENT INDIA PVT LTD**

ADDRESS: No. 8/110, GST ROAD, PALLAVARAM, CHENNAI 600 043, TAMILNADU, INDIA.

MOBILE: +9173582 55571 | +9186672 79007

EMAIL: sales@poclane.com | WEB: www.poclane.com



**POCLANE**