

POCLANE



PLX29U MINI EXCAVATOR



Model	: YANMAR 3TNV80
Rated Power	: 21 HP/2400rpm
Operating Weight	: 2900kg
Bucket Capacity	: 0.09 m ³

Technical Specifications

ENGINE

Model	YANMAR 3TNV80
No. of cylinder	3
Max. Torque/Speed	61/1600N·m/rpm
Displacement	1.123L

HYDRAULIC SYSTEM

Max. Main Pump Flow	95 L/min
Main Safety Valve Pressure	22 MPa

MAIN PERFORMANCE

Bucket Digging	24kN
Force Arm Digging	15.1kN
Force Max. Traction	29kN
Rotary Speed	10 r/min
Gradeability	30°
Ground Pressure	27.3kPa

REFILLING CAPACITIES & LUBRICATIONS

Fuel Tank	33L
Cooling System	5L
Engine Oil	3.4L
Hydraulic Oil Tank	22L

OPERATING WEIGHT & GROUND PRESSURE

Shoe Width	300mm
Ground Pressure	27.3kPa
Operating Weight	2890kgs

SWING SYSTEM

Swing Motor Type	Cycloidal Motor
Swing Speed	0-10r/min
Brake Type	Pressure release mechanical braking

DIMENSION (boom : 2090 mm arm : 1300 mm)

A	Transport Length (arm lowered)	4200
B	Overall height (top of canopy)	2480
C	Undercarriage width	1550
D	Undercarriage length	2020
E	Upperbody width (zero tail)	1400

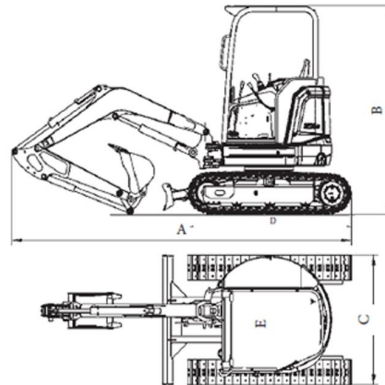

WORKING RANGE

A	Max. digging height	4390
B	Max. dumping height	3060
C	Max. digging depth	2800
D	Max. vertical digging depth	2310
E	Max digging radius	4800
F	Max digging radius, and ground level	4680
G	Min. tail swing radius	775
H	Maximum dozer lift height	300
I	Maximum dozer dig depth	320

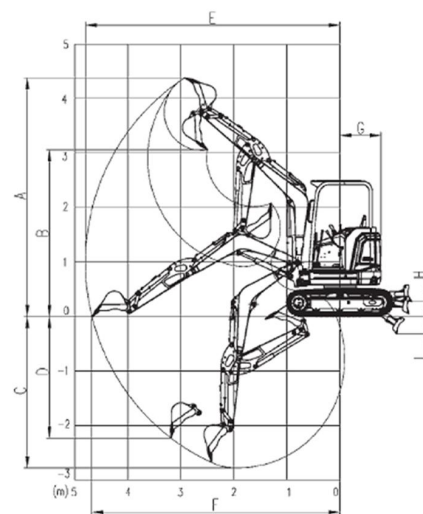

* THE SPECIFICATIONS ARE SUBJECT TO CHANGE WITHOUT NOTICE. THE PICTURES MAY INCLUDE OPTIONS. THE ACTUAL COLOR & APPEARANCE OF THE PRODUCT MAY DIFFER FROM WHAT IS SHOWN.



POCLANE

POCLANE CONSTRUCTION EQUIPMENT INDIA PVT LTD

ADDRESS: No. 8/110, GST ROAD, PALLAVARAM, CHENNAI 600 043, TAMILNADU, INDIA.

MOBILE: +9173582 55571 | +9186672 79007

EMAIL: sales@poclane.com | WEB: www.poclane.com



POCLANE